

## DMX 512 Pixel Decoder

Part number: DMX512-PX



Environmental Lights proudly introduces our DMX 512 Pixel Decoder, the key component for creating intelligent LED lighting. The DMX512-PX is specifically designed to control digitally addressable RGB LED pixel lights using standard DMX512. This decoder is capable of addressing individual LED nodes, when used in conjunction with any of the RGB PixelPro strips or modules. We developed this product in response to many requests from our customers for easy-to-use intelligent RGB LED lighting.

Use the DMX512 Pixel Decoder to create unique animated RGB color effects, such as chasing, rotating graphic patterns, rain effects, pixel display text boards, color wave backlit panels, the possibilities are endless! The DMX512-PX is a reliable way to control intelligent RGB LED lighting and can even be connected in a daisy chain, customizable for any type of installation. Compatible with either a 3 or 5-pin DMX output from your DMX console. The DMX512 Pixel Decoder simply ignores the audio data from the 2 extra pins, if connected to a 5-pin DMX output.

This product is compatible with WS2801 IC chips. We conducted extensive tests on a number of IC chips and chose the best one on the market to sell to our customers. The WS2801 chip provides the widest range of colors, is faster, more efficient, and overall performs better than other IC chips on the market. Our DMX512 Pixel Decoder makes RGB PixelPro LED lights easy to customize and control. Compatible with standard DMX output from a DMX light board or DMX control system. The DMX512-PX converts standard DMX output into SPI protocol for the WS2801 chip, thereby enabling simultaneous control of each individual RGB LED.

The RGB PixelPro line comes in an assortment of individually addressable RGB LED pixel strip and modules in various shapes and sizes. We currently offer RGB PixelPro in 7 configurations: square, bullet (square base option), circular, mini dome, dome, strip (waterproof and non-waterproof), and rectangle.

Examples of RGB PixelPro LED lights you can control with the DMX512 decoder.

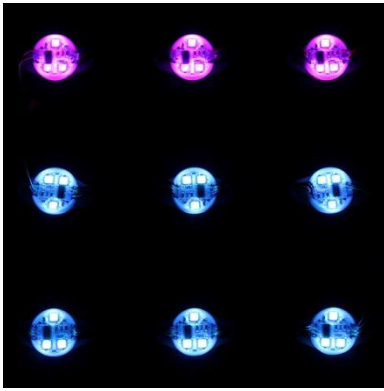

RGB PixelPro 30mm  
Circle Modules

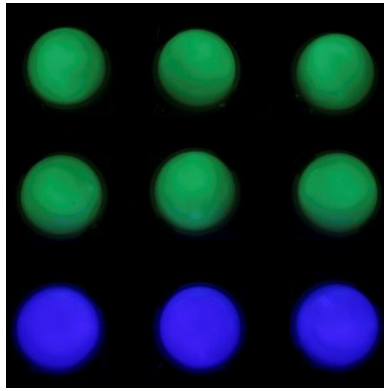

RGB PixelPro 50mm  
Waterproof Domes

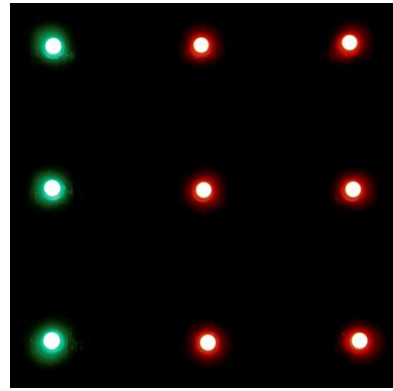

RGB PixelPro bullets



Waterproof RGB PixelPro  
LED Rectangle Module

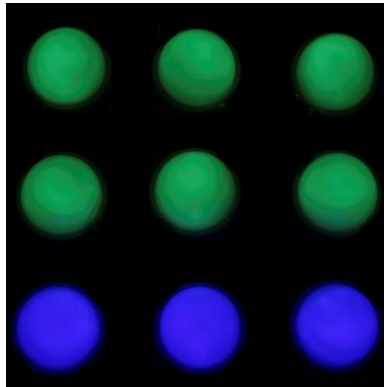

RGB PixelPro LED  
Mini Dome Module



RGB PixelPro LED  
Strip Light

Examples of Monochrom PixelPro LED lights you can control with the DMX512 decoder.



RGB PixelPro 30mm  
Circle Modules

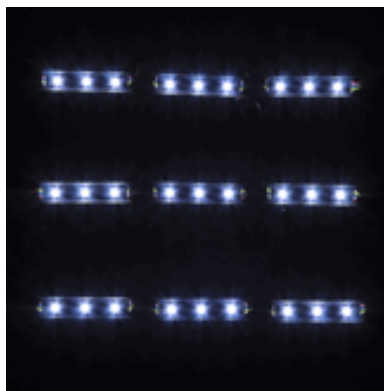

RGB PixelPro 50mm  
Waterproof Domes

# DMX512-PX

## Specifications

Dimensions: 4.92" x 2.05" x 1.57"  
125 mm x 52 mm x 40 mm

Outputs: V+, CLK, DATA

Operating Temperature: -4 to 150°F (-20 to 65°C)

Voltage: 5 to 24 Volts DC

## Features

- Powered by 5-24 VDC.
- DC+ Input power to decoder feeds into DC+ input power for connected PixelPro lights.
- **Built in functional test modes, active when DIP switch 10 is “on”.** For dynamic modes (color step and color fade), speed is controlled by toggling the dip switches 1-5.

Dip Switch Settings	
1000000001	Red
0100000001	Green
0010000001	Blue
0001000001	Yellow
0000100001	Purple
0000010001	Cyan
0000001001	White
0000000101	Color Step
0000000011	Color Fade

- Compatible with standard DMX512 output, enabling individual pixel control.
- XLR3 male and female interface.
- Decode a maximum of 512 DMX addresses, when DIP switch 10 is “off”.
  - 170 pixels of PixelPro LED strip light *or* 170 modules of PixelPro LED bullets, domes, circles, squares, or rectangles.
- Converts standard DMX output to digital SPI signals suitable for driving the WS2801 IC chip.
- Compatible with the PixelPro line of individually digitally addressable RGB LED strip lights and modules, available in 5 VDC or 12 VDC.
- Outputs are clock and data signals, defined independently under direction of the DMX input signal.

- DIP switches on the side allow you to set the decoder's lowest address so it uses the address you desire from your DMX program. Each decoder has a DMX device address you can set. **Default setting with all switches OFF = 1.**

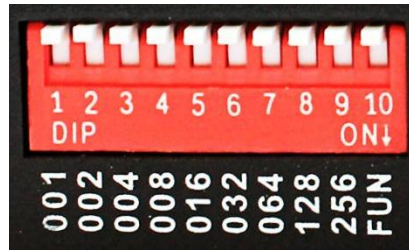

DIP switches to set address

\*\*Please note: An address bit is set ON and has a value = 1 in the down position

- 0 to 110°F recommended operating range.

## Applications

- Create animated effects for studios, stage lighting, architectural, or decorative purposes.
- Use for any application requiring conversion of DMX to WS2801 SPI signals for driving PixelPro2801 LEDs.
- An economical and easy solution for full color intelligent LED lighting control systems.

## Connections

The DMX512-PX 3-pin XLR IN and OUT ports are shown in the figure below:



**Figure 1:** DMX512 Input (3-pin) and DMX serial OUT port

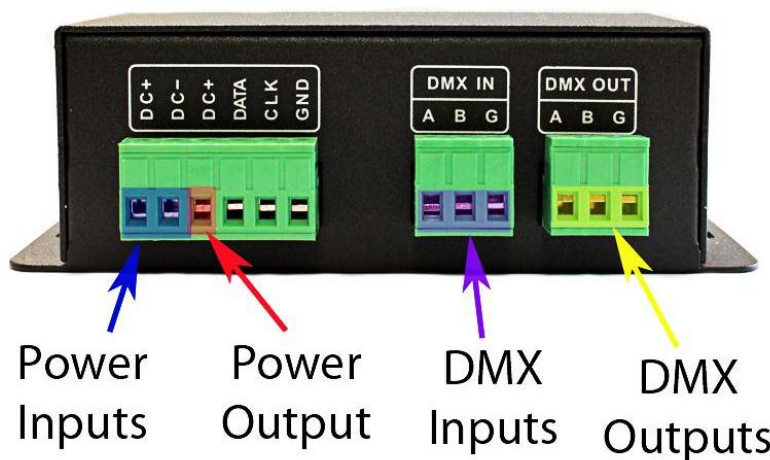

**Figure 2:** Power (5-24 VDC) and DMX Input via connector blocks

The DMX512-PX is compatible with standard 3 or 5-pin DMX outputs from a DMX console. The decoder simply ignores the audio data from the 2 extra pins, if connected to a 5-pin DMX output. Alternatively, DMX IN can be supplied via the DMX IN A (positive), DMX IN B (negative), and DMX IN G (ground) ports through the terminal blocks. Use only one DMX512 IN connection method at a time.

See Figure 1 and 2 above for the DMX input options. If your installation calls for daisy-chaining decoders, use a XLR 3-pin male to 3-pin female to connect to the next decoder (cable not included). See wiring diagram on page 5 for details on how to daisy chain the decoders.

Power the DMX512-PX decoder using 5-24 VDC. **Never apply voltage to the decoder, except through the power input ports, as this will damage the decoder.** The only signals generated by the decoder are clock and data.

Required input voltages for the PixelPro LED lights vary by type, so be sure to pay careful attention to the input voltage. We recommend using a separate power supply to inject power into additional PixelPro LED lights connected in series, as this will create a more stable light system and prevent color variation due to voltage drop. **Applying 12V to modules or strip requiring 5V will destroy the product.**

**IMPORTANT: Be sure to connect all common ground wires between power supplies, strip, modules, etc.**

## Connecting PixelPro LED Lights

DMX512-PX Decoder  
Daisy Chain  
Wiring Diagram



Output data (DATA) and clock (CLK) signals, which are generated by the decoder, connect to the input clock and data lines on your PixelPro LED lights.

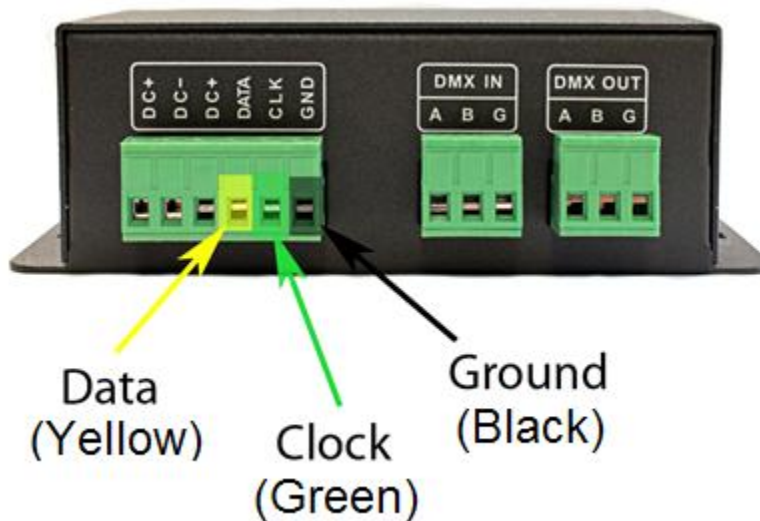

Connect the ground (GND) terminal on the decoder to the black wire ground input on the PixelPro LED lights. When using multiple power supplies, the ground wires (negative terminals) from each power supply must also share the same common ground. If all grounds are not connected, then the PixelPro lights will display erratic behavior, such as rapid flashing or flickering. Be sure to connect all ground wires together, since the power supplies must share a common ground.

# Circuit Diagram

Below is a circuit diagram that illustrates how to wire the DMX512 Pixel Decoder for individual pixel control of your PixelPro lights. In this diagram the Easy Stand Alone DMX controller is used to control the PixelPro LED lights, but you can use any console that outputs standard DMX. Keep signal lines away from power lines to avoid inductive coupling and signal corruption.

DMX512-PX Decoder

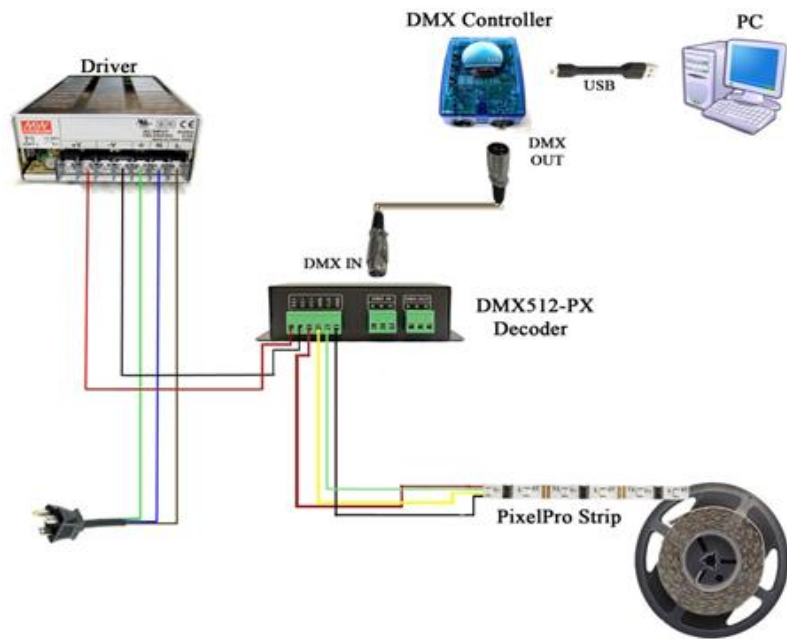

Be sure to match the voltage of the driver to the required voltage of the PixelPro lights.

5 VDC	12 VDC
RGB PixelPro LED Strip Light	RGB PixelPro LED Dome Module
Waterproof RGB PixelPro LED Strip Light	RGB PixelPro LED Circle Module
RGB PixelPro LED Bullet	RGB PixelPro LED Square Module
RGB PixelPro LED Bullet (Square Base)	RGB PixelPro LED Mini Dome Module
	Waterproof RGB PixelPro LED Rectangle Module
	Waterproof Warm White PixelPro LED Rectangle Module
	Waterproof Daylight White PixelPro LED Rectangle Module

## Controlling RGB PixelPro LED Lights

The white DIP switches located on the red block are used to set the DMX address of the decoder. DIP switch 1 is the least significant address bit, and 9 is the most significant. DIP switch 10 engages the functional test mode, and should be set “on” only when DMX control is **not** desired.

Default setting with all switches OFF = 1. When setting the DIP switches the actual address will always be the value set+1. So, for example if you are setting the decoder to read the first address from the DMX output, the setting for the DIP switches should be all OFF in the up position.

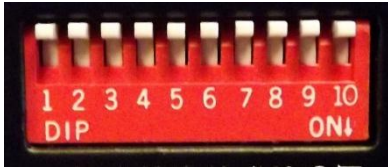

Address “1” Setting

Each RGB pixel requires 3 addresses to control red, green, and blue. A pixel is the smallest controllable element in a given light medium. One pixel can contain one or more LEDs. For example, when referring to RGB PixelPro strip light, one pixel is equivalent to 1 LED. On the other hand, when referring to a string of RGB PixelPro LED Square Modules, one pixel is equivalent to 4 LEDs or one module.

## Controlling RGB PixelPro LED Lights with Multiple Decoders

If your installation calls for daisy-chaining decoders, follow the example below as a guideline on how to set your DIP switch settings. Link multiple decoders using a 3-pin to 3-pin XLR cable.

DIP	1	2	3	4	5	6	7	8	9	10
Address	001	002	004	008	016	032	064	128	256	FUN

For this example, we will create an installation using three strings of our RGB PixelPro bullets and three decoders. Each string contains 50 LEDs and requires  $(50 \times 3) = 150$  addresses to individually control the RGB colors of each pixel, so the DIP switch settings will be as follows. The actual corresponding addresses are listed in comment section.

String	DIP Switch Settings										Comment
	1	2	3	4	5	6	7	8	9	10	
1	0	0	0	0	0	0	0	0	0	0	binary 000000001 = address 1"
2	0	1	1	0	1	0	0	1	0	0	binary 010010111 = address 151"
3	0	0	1	1	0	1	0	0	1	0	binary 100101101 = address 301"

DIP switch 10 should always be “off” when in DMX mode. Keep signal lines away from power lines to avoid inductive coupling and signal corruption.

## Controlling Monochrome PixelPro LED Lights

We currently offer two monochrome options:

- Waterproof Warm White PixelPro LED Rectangle Module
- Waterproof Daylight White PixelPro LED Rectangle Module.

Similar to RGB PixelPro lights, each module requires 3 addresses to control three separate channels of white. For example, one string of 20 Waterproof Warm White PixelPro LED Rectangle Modules requires  $(20 \times 3) = 60$  addresses to individually control the dimming of each pixel.