

LED Magnetic Channel System



Fast and Secure Installation

The LED Magnetic Channel System both simplifies the installation of LED strip light and provides a durable and rigid housing. The LED Magnetic Channel System reduces installation time by magnetically adhering to metal surfaces securely and without any additional hardware. The LED Magnetic Channel System includes two elements: our high-quality, magnetic aluminum channel and a compatible frosted diffuser.

The magnets of the channel system come in pairs and hold each other in place. This results in the magnets not moving from their position in the channel, further strengthening the magnetic hold of the channel system. Additional magnets can be added to strengthen the hold of the channel system.

The MCS172-2m is perfect for any 10mm wide LED strip light product while the MCS173-2m is perfect for any 12mm wide LED strip light product. Simply peel the adhesive backing from the strip, install it into the channel and stick the magnetic channel onto a metal surface.

- Comes in 2 meter segments and can be cut to any length
- Includes aluminum channel, diffuser and magnets
- The frosted diffuser provides a diffused and finished look while protecting the LED strip light
- Compatible end caps are available (sold separately)
- Additional magnets sold separately

LED Magnetic Channel System

Specifications - MCS172-2m, MCS173-2m

MCS172-2m

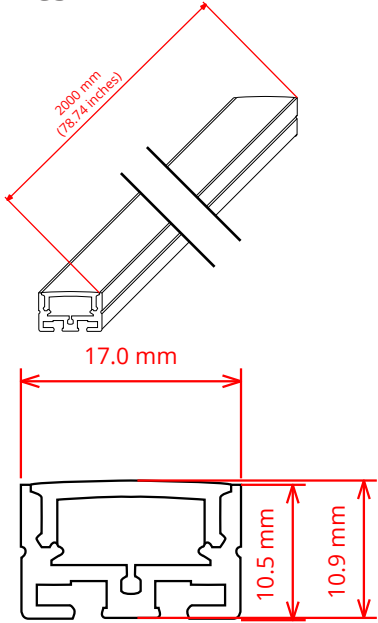

MCS172 Without Diffuser



EL-CAP-166



EL-CAP-166-h



MCS172 With Diffuser



EL-CAP-166 on MCS172



EL-CAP-166-h on MCS172

MCS173-2m

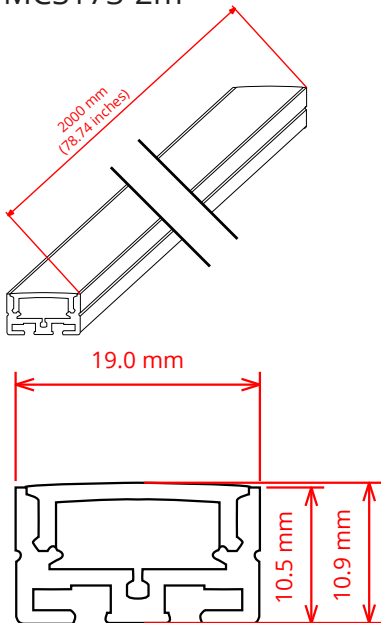

MCS173 Without Diffuser



EL-CAP-167



EL-CAP-167-h



MCS173 With Diffuser



EL-CAP-167 on MCS173



EL-CAP-167-h on MCS173

Magnets can be repositioned anywhere in the channel.

