

## **24 Volt RGB/RGA LED Neon**

Part Numbers: LN-RGB, LN-RGA



LED Neon from Environmental Lights is a unique and special product you probably won't find anywhere else. It is durable, flexible, customizable, easy-to-install, and even waterproof. With LED Neon, you can achieve the look and feel of traditional glass neon without all of the maintenance and durability issues. We are proud to announce that LED Neon is also UL Listed and runs off low voltage 24VDC, so it is safe to use.

Traditional glass neon has been the medium of choice in the sign industry for decades, and gained popularity in the architectural and accent lighting industry over the years as well. However, a large drawback to glass neon is that it is fragile, expensive to maintain, and difficult to customize or repair. This new and improved version of neon is durable, rugged, waterproof, bright, energy efficient, easy-to install, and available in a wide variety of colors.

LED Neon is capable of producing lighting effects that were never possible with traditional glass Neon. LED Neon is easy to dim or control using any of our LED dimming drivers, controllers or pulse dimmers. If you want to take it to the next level, use our LED Neon products with a DMX controller and decoders to create an eye catching light show or use RGB and RGA color changing LED Neon incorporate the element of color mixing, which was also never before possible with traditional glass Neon.

It is easy to customize and create impressive large scale effects using LED Neon. We provide all of the tools, accessories, and instructions that are needed to customize your project. Based on the needs of the project, LED Neon can achieve a waterproofing level of up to IP68 when custom injection molded. Also, there are two types of aluminum channel (standard and self-locking) that are compatible with LED Neon. For both versions, simply use screws to mount the channel, then install the LED Neon into the channel.

## Specifications

Voltage:	24VDC
Power consumption:	12 watts per meter (3.7 watts per foot)
Dimensions:	11.5mm x 21mm (0.45" x 0.90")
LED quantity:	60 LEDs per meter
Minimum cutting length:	100mm (3.94")
LEDs per cut segment:	6
Minimum bending diameter:	120mm (4.72")
Waterproof rating:	IP65-IP68 (connectors must be applied as described below)
Certifications:	UL, RoHS
Warranty:	3 years limited

## Warning

- Before making any cuts or performing installation/maintenance, be sure all electricity is disconnected.
- Custom injection molded or double injection molded ends must be applied to obtain IP67 or IP68 rating.
- Operate LED Neon lighting according to instructions only.
- Confirm the polarity of connectors before inserting.
- Connect and cut this product correctly. **Must use cutting shears designed to cut LED Neon (listed in accessories tab).**
- Incorrect operation will damage the circuitry.

## Caution

- Use only factory-recommended shears, connectors, and accessories.
- Do not operate in more than 45°C (110°F) ambient temperature.
- Do not operate light when ambient temperature is below -20°C (-4°F).

# Assembly and Installation

1. Be sure to mount the LED Neon correctly, as illustrated by figures 1-4.

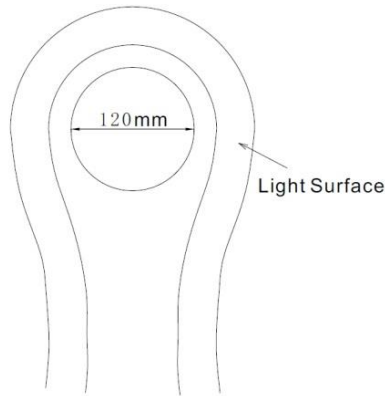

Figure 1: Minimum bending diameter is 120mm (4.72").

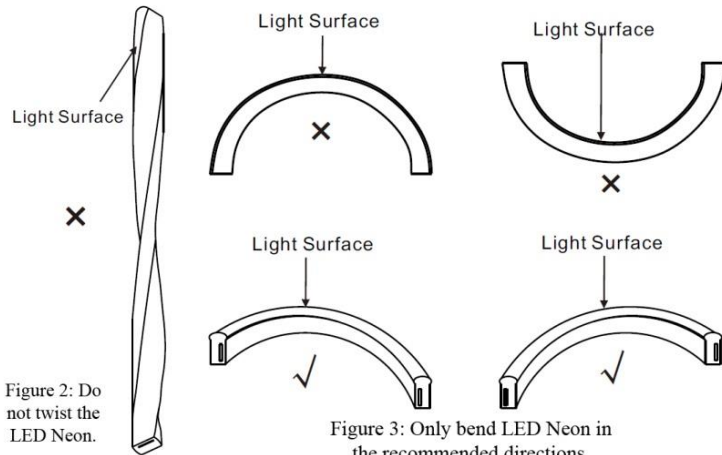

Figure 2: Do not twist the LED Neon.

Figure 3: Only bend LED Neon in the recommended directions.

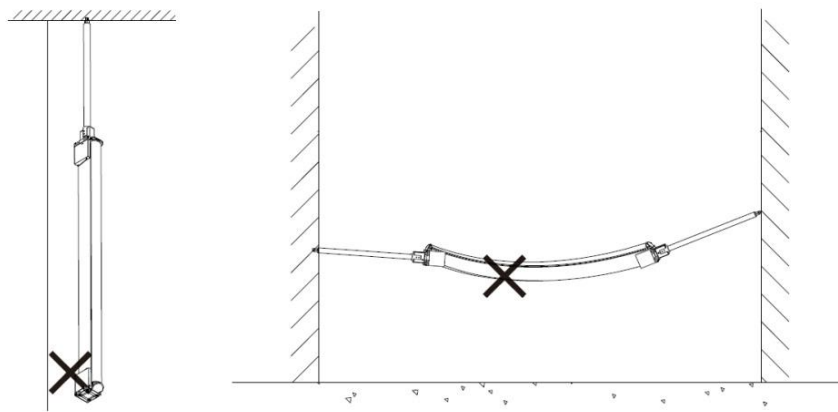

Figure 4: LED Neon must be properly supported when mounted. Do not hang.

2. LED Neon can be cut every six LEDs at specific cut points. Dotted lines on the side of the rope indicate where cuts can be made. Be sure your cut is a straight line, perpendicular to the rope light, as shown below.

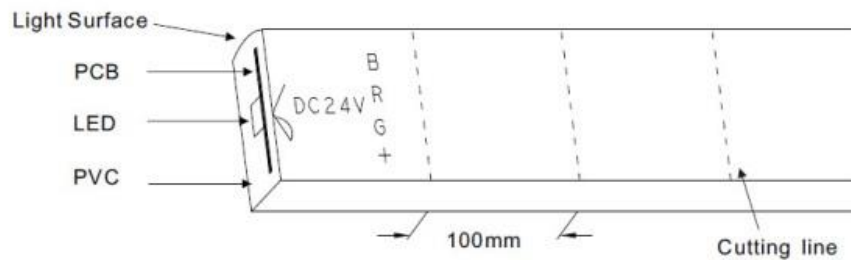

Figure 5: LED Neon can be cut every six LEDs. Be sure to cut only along the cutting lines.

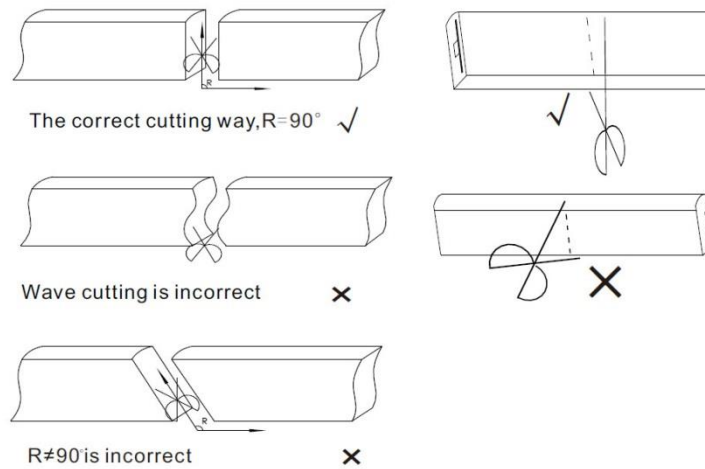

Figure 6: Be sure to cut perpendicular to the LED Neon.

3. Wire colors: red, green, and blue wires correspond to the red, green and blue lines. Yellow wire corresponds to the V+ line.
4. Make sure to insert pins in the correct direction. The 01 and 02 Front and End Connectors are mirrored in terms of the direction of pins. Always check the functionality after inserting a connector and before sealing the connection to ensure that the proper directionality has been achieved.

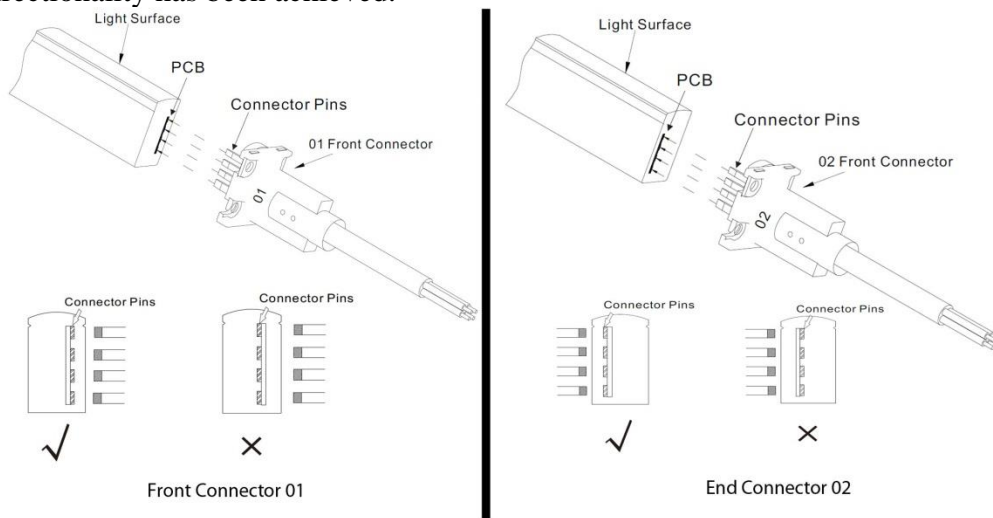

Figure 7: Be sure to insert pins in the correct direction.

① Single end connection for Max. length 10m



② Both ends connection for Max. length 20m



Figure 8: If powering from one end, maximum run length is 10m (33 feet).  
If powering from both ends, maximum run length is 20m (65 feet).

5. Connecting your accessories properly is key to maintaining the lifetime of the LED lights. 20 meter reels will be received with a front connector fully sealed onto each end.
6. Below are instructions for assembling the snap connector series:

Insert the placement tool on the back side of the PCB and gently move the tool side to side to create enough space for the connector pins.

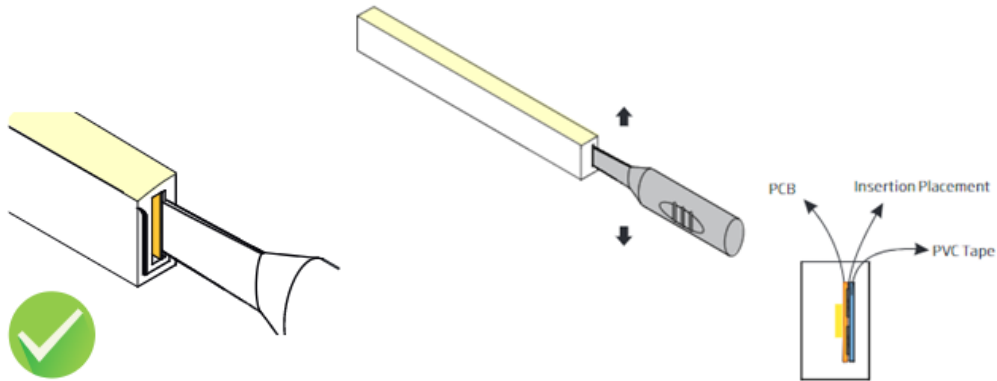

Insert the connector pins on the back side of the PCB. A small 2-5mm gap will exist between the connector and the neon surface. This gap will be eliminated once the metal bracket is in place.

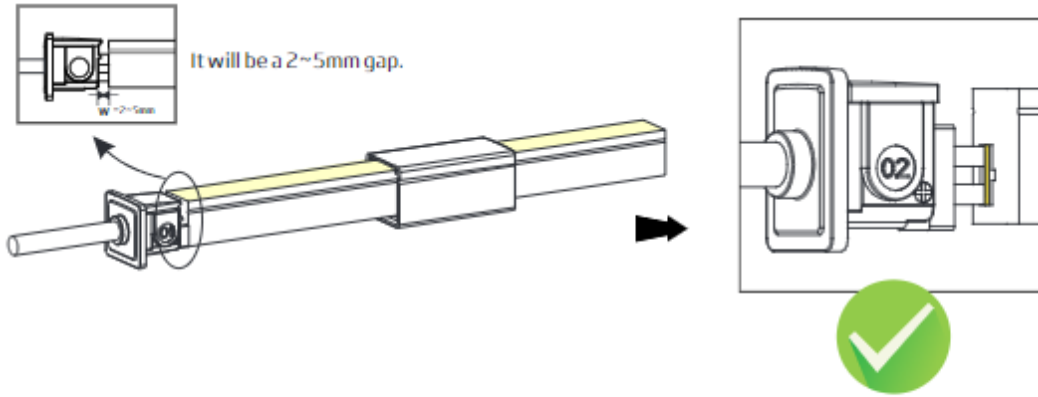

The following operations are prohibited:

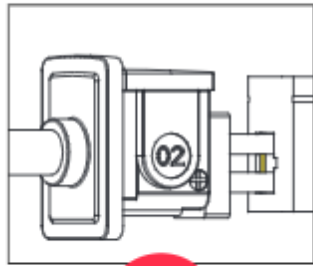

Insert into the front side of the PCB

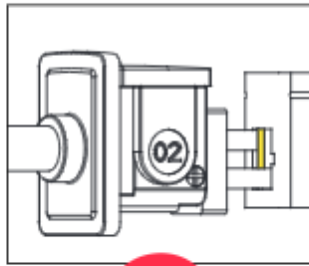

Insert crosswise into the PCB

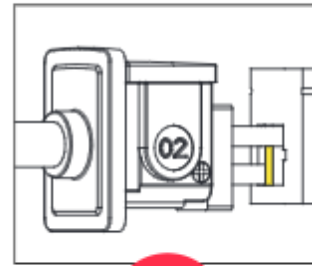

Insert crosswise into the PCB

Proper installation of the connector components:



Unfold the anti-skidding clip about 20 degrees on both sides.

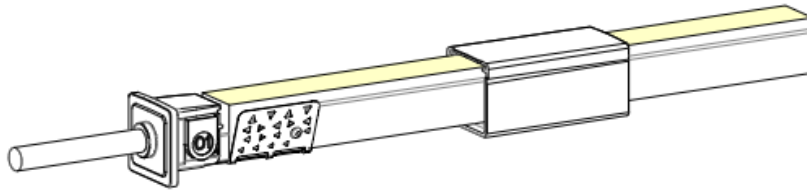

Place the anti-skidding clip onto the assembly end of the light.  
Pay attention to its direction

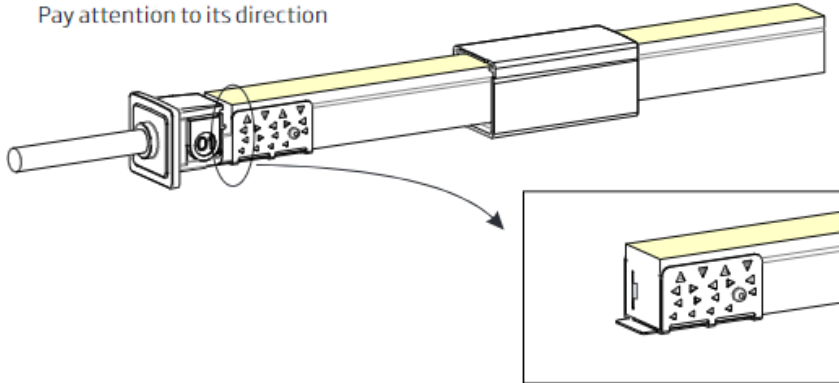

Fit the anti-skidding clip to the end of the light so that it wraps tightly and its brim is aligned with the cut edge on both sides.

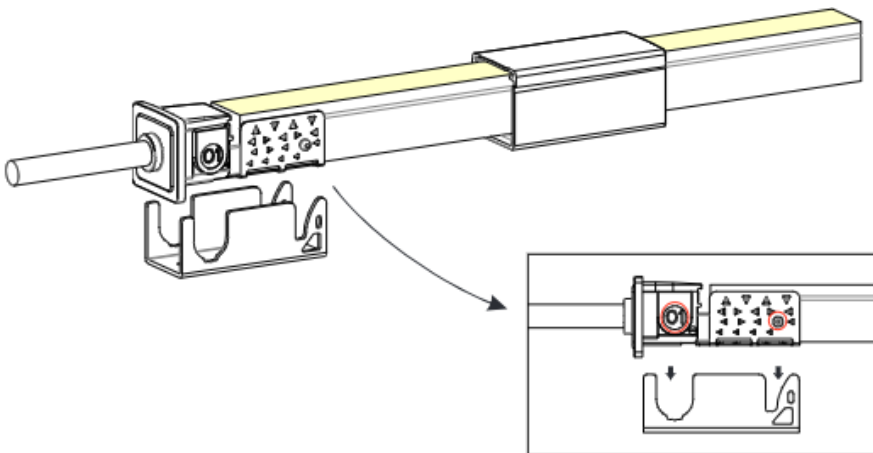

Push metal bracket into place and aligned placement with the areas highlighted above.

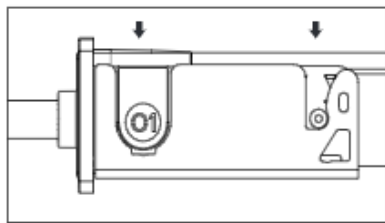
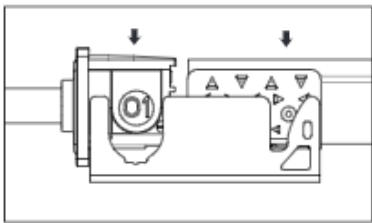
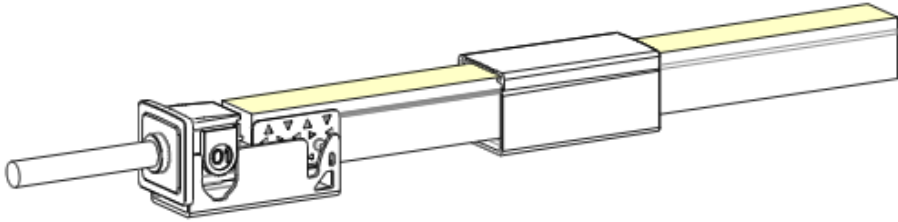

Press the feed connector and light downwards at the same time till bottom.

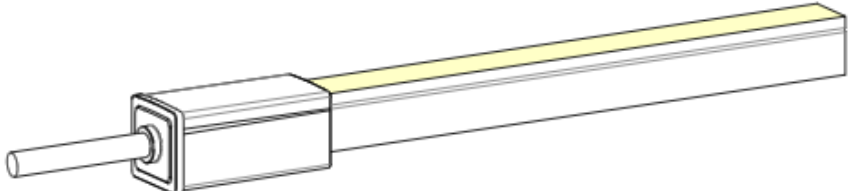
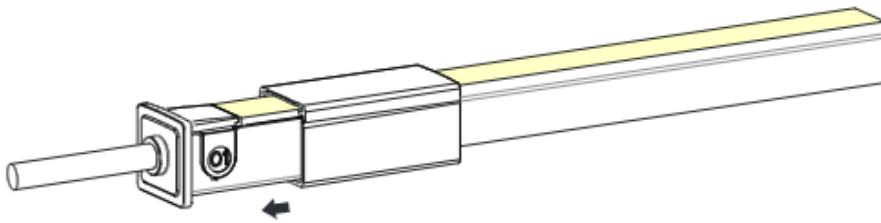

Slide the snap cover towards the connector until it snaps into place.



7. Follow the instructions below for the 40 series accessories. HST stands for Heat Shrink Tube.

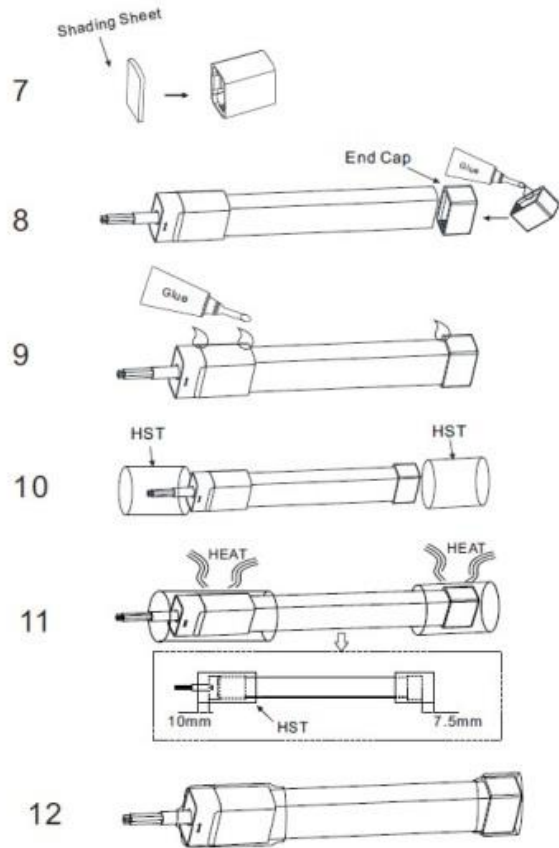
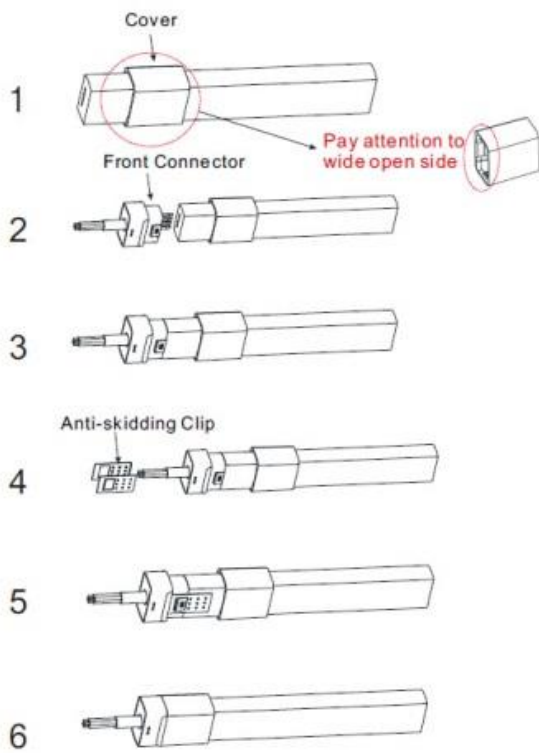
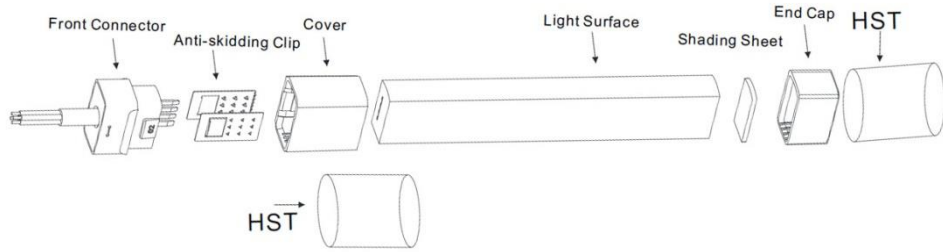

8. Follow the instructions below for the 68 series accessories (discontinued).

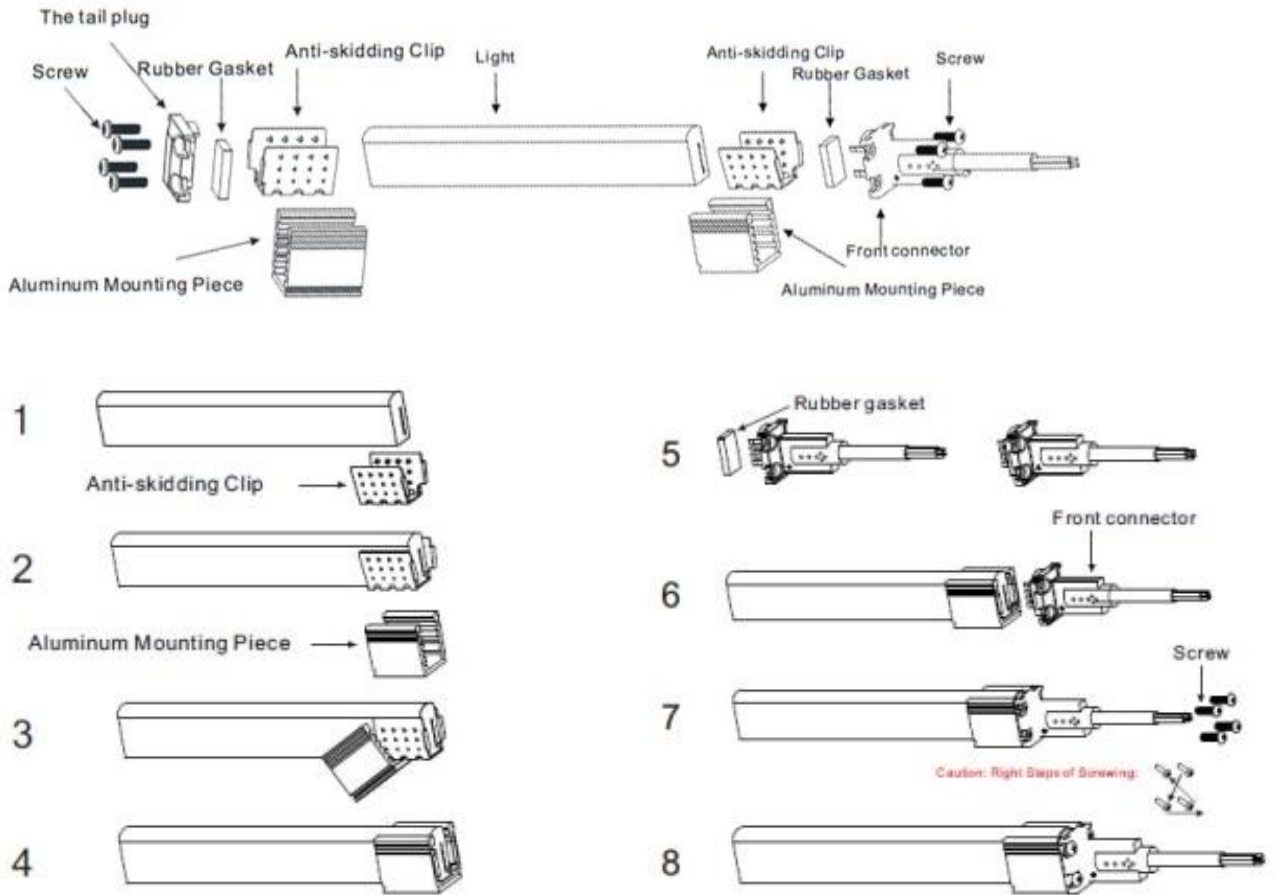

End cap assembly.

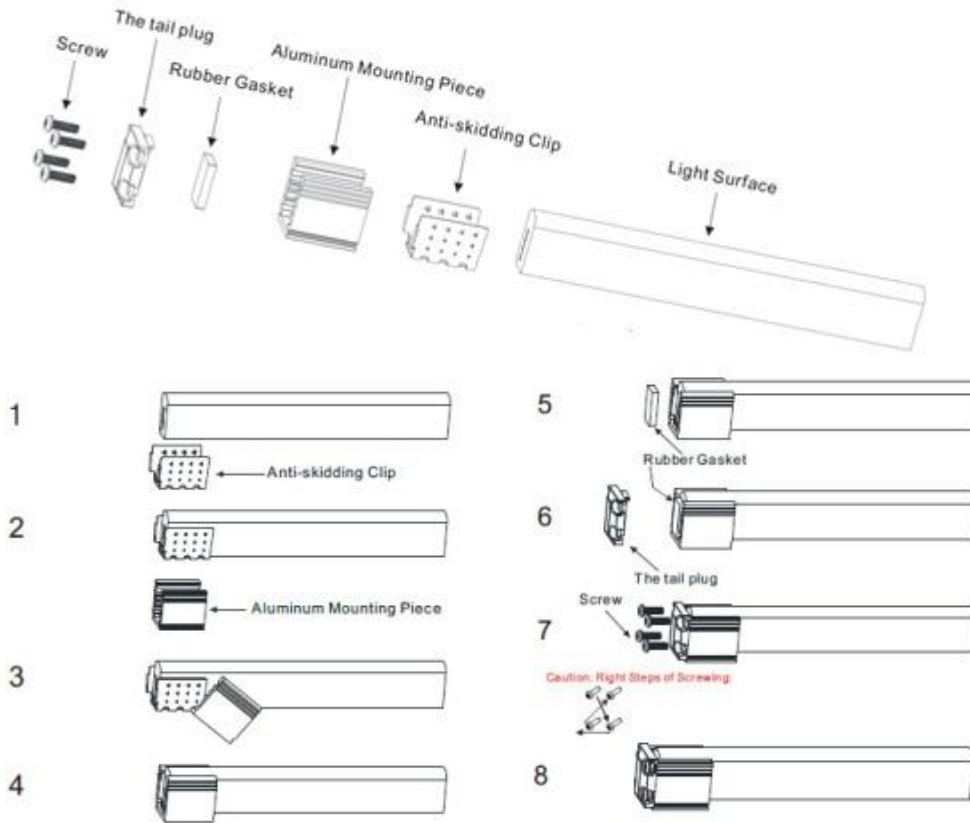

9. There are two types of aluminum channel that are compatible with LED Neon. For either, use screws to mount the U-channel, then install the LED Neon into the channel.

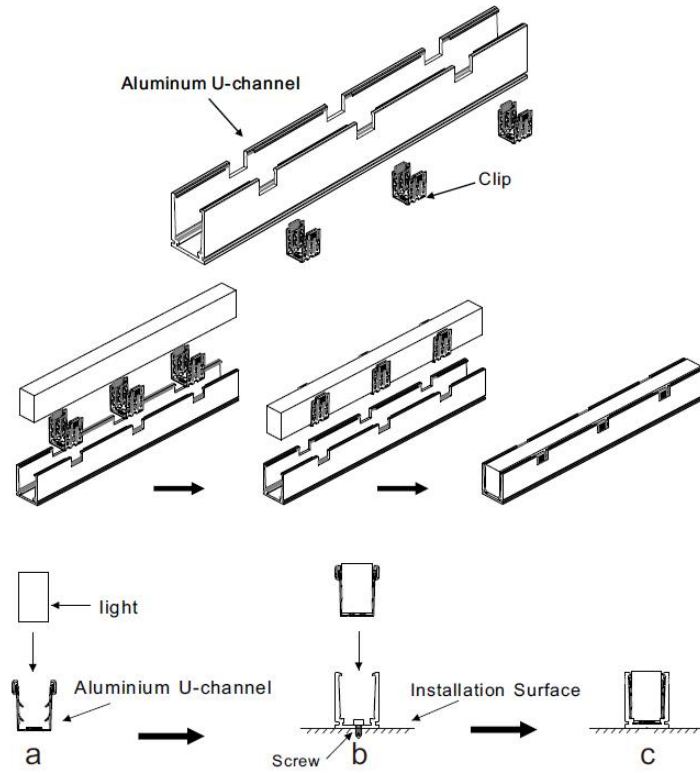

Figure 13: U-Notch Self Locking Aluminum Channel

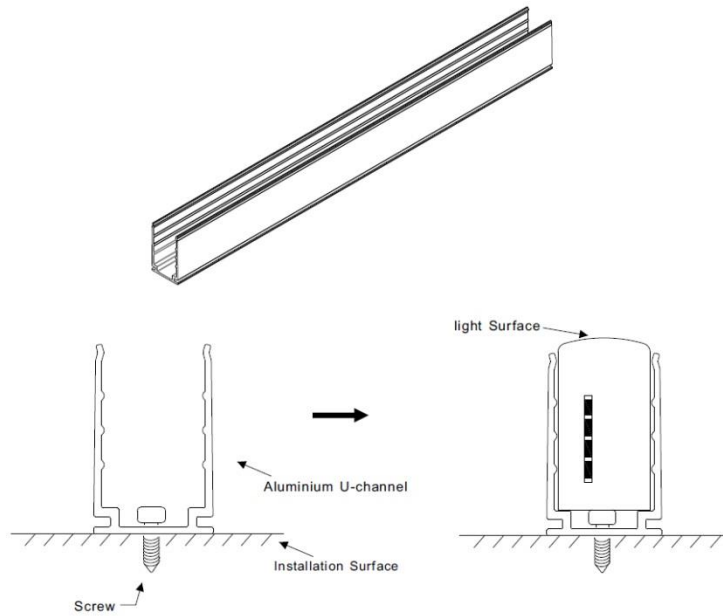
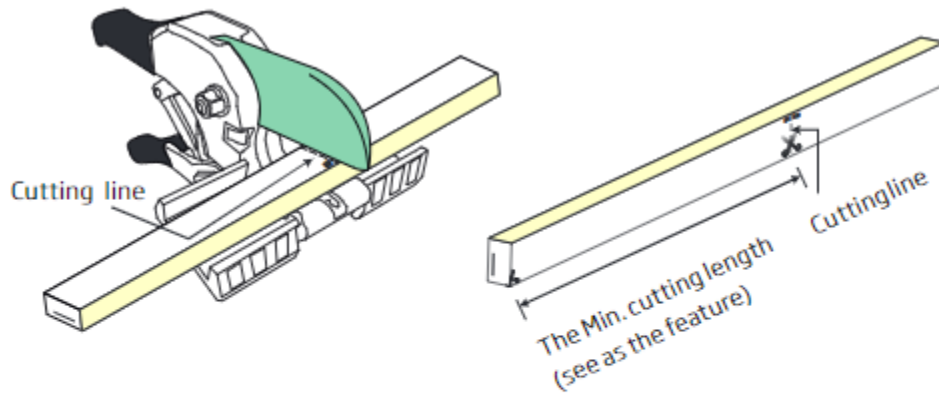

Figure 14: Basic U-Channel for LED Neon

## Cutting Instructions

1. Use only the recommended shears (see accessories tab).
2. Place LED Neon on a horizontal surface when cutting (cut perpendicular to light surface) and ONLY cut where the indicated cutting lines are printed.



Note: The cutting surface should be flush and smooth.

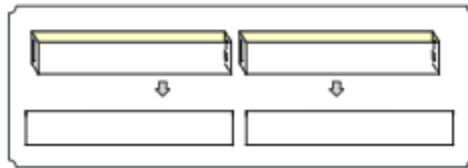

## Instructions

Please take the following precautions:

1. This equipment, like all electrical equipment, should be installed by a qualified person.
2. Do not expose these LEDs, dimmers or power supplies to intense electro-magnetic fields, including lightning.
3. The controllers and power supplies are not waterproof. Keep them dry.
4. Always observe proper polarity.

When installing LED lighting, it is a good idea to follow this “dry-run” procedure:

1. Be sure you have everything you need before you start.
2. Lay out your lights and power supply on the floor or table.
3. There is some resistance in the LED lighting. If you see any color fading or dimming at the end of a long run, you may have too many LEDs for your power supply and you might need a bigger supply or shorter runs. Use a bus structure as described in [rgb\\_manual.pdf](#). Call if you need assistance with larger projects.
4. Connect everything and test it to be sure it works and you have it connected properly. It is unlikely, but possible, that some part of your system is defective or was damaged during shipment. If that is the case, it will be very helpful to you to know that before you do all the work involved in installing custom LED lighting systems. You will also know if you damage anything during installation, which is really helpful in trouble-shooting because manufacturing defects and installation damage typically have very different solutions.

Once you have tested the system successfully, you are ready to install it. We recommend you install LEDs, electronic controls and dimmers in such a way that you have access to them in case they fail. All electrical components can fail.