

# ILUMINARC®

## ILUMIPOD LOGIC TRI-4 OPTIC 25 RGB

Item Number: 21004001

Client: \_\_\_\_\_

Project: \_\_\_\_\_

Date: \_\_\_\_\_ Type: \_\_\_\_\_

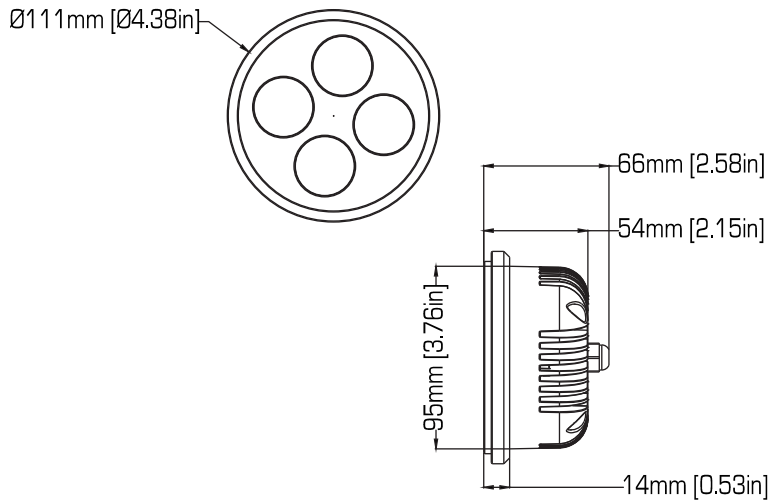

### LIGHT SOURCE & OPTICAL SPECIFICATIONS

Light Source: 4 LEDs (Tri-color, RGB) 3 W (1,050 mA)  
Light Source Lifespan: 50,000 hours based on LED manufacturer's specifications  
Installed Optics: 25°  
Beam Angle: 16°  
Field Angle: 29°  
Lumens: 351  
Base Illuminance: 139 lux @ 5 m  
Efficacy: 19 lm/W  
Color Temperature Presets: N/A  
Minimum Distance to Illuminated Surface: 4 in (92 mm)

### CONSTRUCTION & PHYSICAL SPECIFICATIONS

Diameter: 4 in (111 mm)  
Height: 2.6 in (66 mm)  
Weight: 1.4 lb (0.6 kg)  
Color: Brushed aluminum  
Ingress Protection Rating: IP20  
Housing Material: Cast and extruded aluminum  
Lens Cover: N/A  
Installation Orientation: Any

### CONTROL SPECIFICATIONS

Control Protocol: USITT DMX-512a, via LOGIC Driver  
Control Channels: via LOGIC Driver  
Operating Modes: via LOGIC Driver  
Stand Alone Control: N/A  
Remote Addresser: N/A  
Data Connection: 6.6 ft (2 m) RJ45

### ELECTRICAL SYSTEM SPECIFICATIONS

Input Voltage: From LOGIC Driver  
Power and Current: 18.5 W, 350 mA @ 48 V  
Power Supply: Electronic external  
Dimmer: N/A  
Power Linking: N/A  
Power Connection: 6.6 ft (2 m) RJ45

### THERMAL SPECIFICATIONS

Cooling: Convection  
Startup Temperature Range: 68 °F to 104 °F (20 to 40) °C  
Operating Temperature Range: 68 °F to 104 °F (20 to 40) °C  
Storage Temperature Range: 68 °F to 104 °F (20 to 40) °C

### REGULATORY & VOLUNTARY QUALIFICATION

Certification Listings: ETL, CE  
Environment: Dry location, IP20  
Warranty: 36 month manufacturer's limited warranty (for covered regions only)

Product  
Web Page



[WWW.ILUMINARC.COM](http://WWW.ILUMINARC.COM) - [INFO@ILUMINARC.COM](mailto:INFO@ILUMINARC.COM)

Iluminarc reserves the right to make improvements to this product  
and its specifications at anytime without notice.

ILUMINARC.  
5200 NW 108th Ave.  
Sunrise, FL 33351  
+1.954.923.3680

# ILUMINARC®

## ILUMIPOD LOGIC TRI-4 OPTIC 25 RGB

Item Number: 21004001

Client: \_\_\_\_\_

Project: \_\_\_\_\_

Date: \_\_\_\_\_ Type: \_\_\_\_\_

### Illumipod LOGIC Tri-4 Optic 25 RGB

- Beam Angle: 16°
- Field Angle: 29°

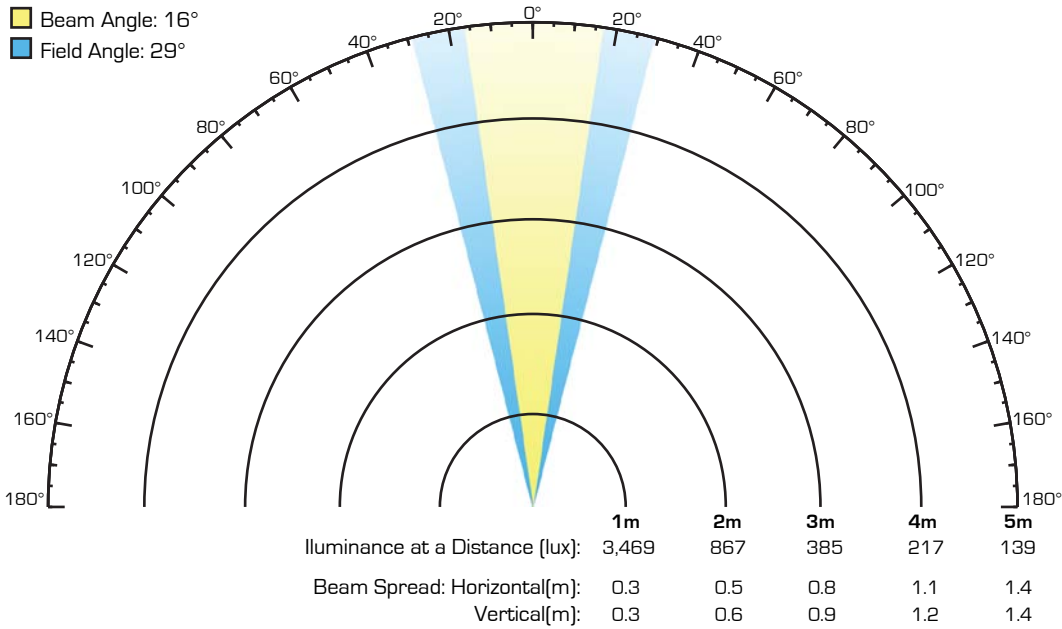

### ILUMIPOD LOGIC TRI-4 OPTIC 25 RGB Typical Installation

