

REVI

Remote-Voltage Illumination System



REVI OVERVIEW

The REVI Remote-Voltage Illumination System from Environmental Lights is a low voltage downlighting solution designed with A/V integrators, for A/V integrators. It was created to expand integrator offerings to downlighting and empower them to “own the ceiling”. Available for residential and commercial applications with recessed and pendant solutions from 400 to 10,000 lumens.

The REVI system is composed of two main elements:

- REVI Power Supplies
- REVI Downlight Fixtures

REVI POWER SUPPLIES

The REVI Power Supplies are RDM enabled and feature programmable Class 2 outputs which provide unprecedented flexibility over configuring the drivers and monitoring their performance. This level of control makes designing the lighting system much easier while simplifying the range of power supplies they need to run low voltage lighting.

- Available in 4 or 12 channels
- Customizable drive currents on every channel
- Rack mountable
- RDM enabled for performance monitoring
- UL Listed and Class 2

REVI DOWNLIGHTS AND PENDANTS

REVI Low Voltage Downlighting Fixtures are engineered for architectural and residential applications. REVI 3-inch Downlights feature à la carte options that enable users to configure the fixture for their exact application. Options are available from the light engine output all the way to the shape and look of the final trim. Integrators can get the exact fixture they want.

REVI XL Pendants are designed for architectural applications where larger areas need light coverage. These high-output pendants are ideal for houses of worship and auditorium projects.

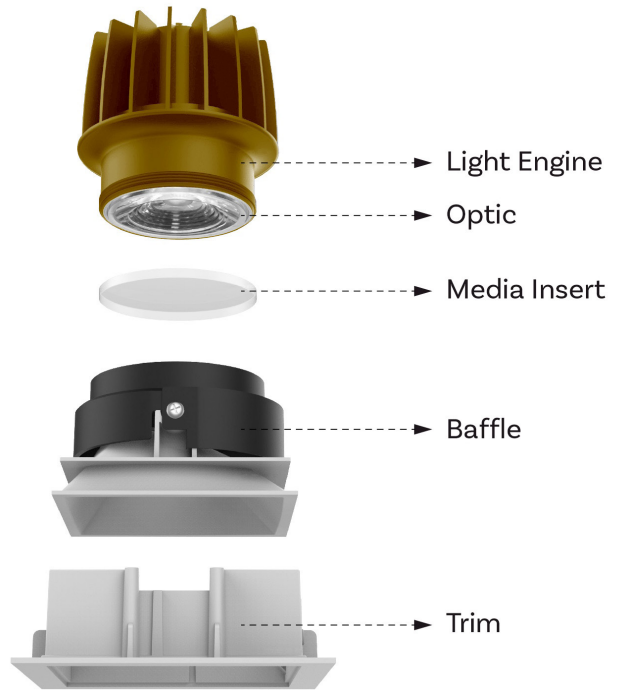

REVI SYSTEM EXAMPLE

Example: 12 Channel Configuration with REVI 3-inch Downlight Fixtures

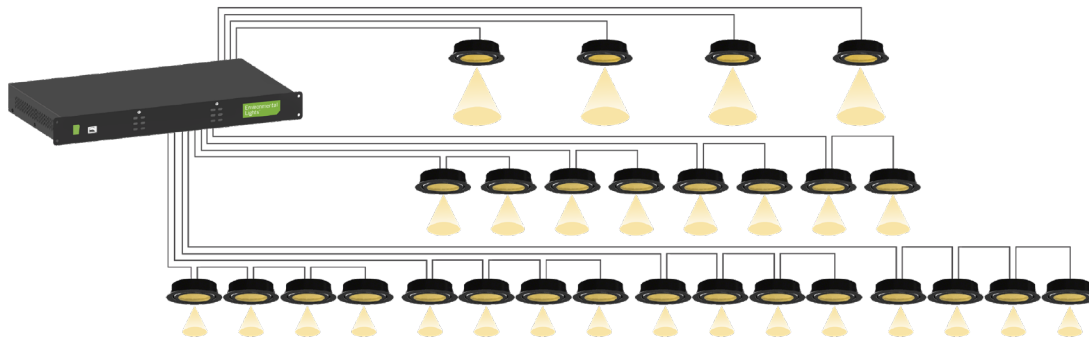

CONTACT US TODAY TO LEARN MORE ABOUT REVI

888.880.1880

ContactUs@EnvironmentalLights.com

Lighting design and support services available!

