

Mini Occupancy Sensor with Receiver

Part number: sensor-pir-mini



The Mini Occupancy Sensor with Receiver uses a passive infrared (PIR) sensor to detect movement in a room and automatically turns lights on and off. The sensor detects movement with a range of about three meters (9.8ft) and will automatically switch on the lights when it does. After a 1-minute period of inactivity, the lights shut off again. The sensor head can be placed up to one meter (3.3ft) away from the main body for better detection. This compact unit can also handle up to 8A despite its small size.

Features

- Automatically turns the lights on when an occupant enters the sensor field.
- Turns lights off after 1 minute of inactivity to save energy.
- The sensor can be placed away from the housing for detection in the desired area of the room.
- Small size and sensor cable allows the housing to be mounted out of sight.
- Easy to install.
- Works with any Single-Color LED strip light that uses 12-24V DC.
- Supports up to 8A of current.
- Does not require any additional batteries or controller.

Applications

- Lighting where a traditional switch or controller would be unsightly or difficult to place.
- Small rooms or closets where a light may be accidentally left on.
- Automatic entryway lighting, so there is no need to hunt for a switch in the dark.
- Automatic night lights providing ambient light at night without turning main lights on.

Specifications

Dimensions:	1.46" x 3.78" x 0.83" 37 mm x 96 mm x 21mm
Sensor Length	1m or 3.27ft
Channels:	1
Turn-Off Time	1 minute
Input voltage:	12-36 Volts DC
Max. current load:	8A
Max. output power:	96W/192W/288W (12V/24V/36W)



Operating Instructions

Connect the single color LED power wires to the appropriate secondary (SEC) terminals. Pay close attention to verifying the positive and negative terminals.

1. Verify that the DC power supply is off and that the output voltage matches the required voltage of the LEDs. Connect the wires coming from the 12-24V DC (**depending on the LED's required input voltage**) to the input terminals of the receiver.
2. Plug the PIR sensor head into the other side of the receiver with the three-pin connector and receptacle (included).
3. Turn on the power supply. The LEDs will turn on in response to movement detected by the sensor and off again after 1 minute of inactivity. For some applications, you may want to install an on/off switch between the sensor and LEDs to act as a master off switch.

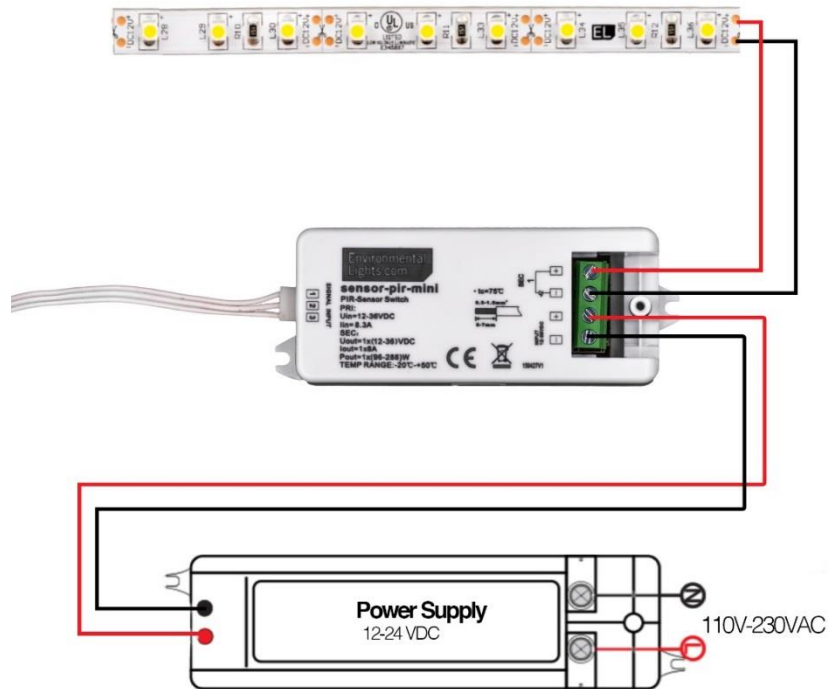

Safety Precautions

Please take the following precautions:

1. This equipment, like all electrical equipment, should be installed by a qualified person.
2. Do not expose these LEDs, dimmers or power supplies to intense electro-magnetic fields, including lightning.
3. The controllers and power supplies are not waterproof. Keep them dry.
4. Always observe proper polarity.

When installing LED lighting, it is a good idea to follow this “dry-run” procedure:

1. Be sure you have everything you need before you start.
2. Lay out your lights and power supply on the floor or table.
3. There is some resistance in the LED lighting. If you see any color fading or dimming at the end of a long run, you may have too many LEDs for your power supply and you might need a bigger supply or shorter runs. Use a bus structure as described in [rgb_manual.pdf](#). Call if you need assistance with larger projects.
4. Connect everything and test it to be sure it works and you have it connected properly. It is unlikely, but possible, that some part of your system is defective or was damaged during shipment. If that is the case, it will be very helpful to you to know that before you do all the work involved in installing custom LED lighting systems. You will also know if you damage anything during installation, which is really helpful in trouble-shooting because manufacturing defects and installation damage typically have very different solutions.

Once you have tested the system successfully, you are ready to install it. We recommend you install LEDs, electronic controls and dimmers in such a way that you have access to them in case they fail. All electrical components can fail.