

Vive PowPak Dimming Module with 0–10 V_{ac} Control

The PowPak Dimming Module with 0–10 V_{ac} Control is a radio frequency (RF) control that operates 0–10 V_{ac} controlled fluorescent ballasts or LED drivers based on input from Pico remote controls and Radio Powr Savr sensors. The Dimming Module with 0–10 V_{ac} Control is ideal for small areas (e.g., classrooms, conference rooms, private offices). Communication with RF input devices (e.g., Pico remote controls, Radio Powr Savr sensors) is accomplished by using Lutron Clear Connect RF Technology.

These products are also compatible with the Vive hub which enables a simple setup process using a standard web browser on any Wi-Fi enabled phone, tablet or computer. It also enables control and monitoring of all Vive devices. The Vive hub can be added at any time. System reprogramming will be required. For a complete list of features supported with the Vive hub, see specification submittal 369902.

Note for Replacement: RMJS/URMJS - the “S” model can replace the non-”S” model.

Features

- Controls up to 60 mA of 0–10 V_{ac} controlled fixtures together
- Switches up to 8 A total
- 0–10 V_{ac} control link automatically sources or sinks to the third party fixtures
- Configurable high- and low-end trim
- Various operating voltages available; refer to model number chart below for details on voltage requirements
- Receives wireless inputs from up to 10 Pico remote controls, 10 Radio Powr Savr occupancy/vacancy sensors, and 1 Radio Powr Savr daylight sensor
- Utilizes Lutron Clear Connect RF Technology; refer to model number chart below for frequency band data
- Mounts to a US-style junction box through a standard-size knockout

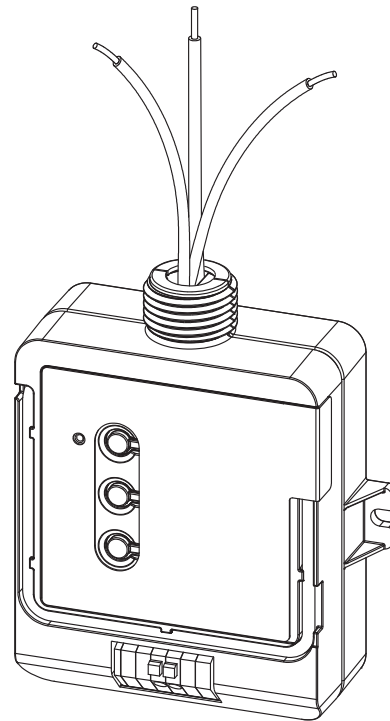

<p>Job Name:</p> <p>Job Number:</p>	<p>Model Numbers:</p>
--	------------------------------

Models

Model Number	Region	Operating Voltage	Frequency Band
RMJS-8T-DV-B	U.S.A., Canada, Mexico	120/277 V~	431.0–437.0 MHz
URMJS-8T-DV-B	U.S.A. (BAA Compliant)	120/277 V~	431.0–437.0 MHz

NOTE: Contact Lutron for frequency band compatibility for your geographic region if it is not indicated above.

Job Name:	Model Numbers:
Job Number:	

Specifications

Regulatory Approvals

RMJS- and URMJS- models

- UL Listed
- FCC approved. Complies with the limits for a Class B device, pursuant to Part 15 of the FCC rules
- Complies with requirements for use in other spaces used for environmental air (plenums) per NEC 2014 300.22(C)(3)
- Listed in accordance to CAN/ULC S102.2-2010 with a Flame Spread Rating of 0 and a Smoke Developed Classification of 40, with a minimum spacing of 6 ft (1.83 m) off center
- cUL and IC (Canada) (RMJS- only)
- COFETEL (Mexico) (RMJS- only)
- NOM (Mexico) (RMJS- only)

Power

- Operating voltage
 - **RMJS- and URMJS- models:** 120/277 V \sim 50/60 Hz

Output Ratings

- Switch rating of 8 A. Rated for resistive or capacitive loads as defined by IEC/EN 60669-2-1
- 0–10 V \equiv control link for 60 mA maximum output, source or sink automatically configures

Other Power Specifications

- Standby power:
 - 240–277 V \sim 610 mW
 - 120 V \sim 550 mW
- BTU/hour when fully loaded: 9
- Works with all ballasts and drivers that provide a current source that is compliant to IEC 60629 Annex E.2, and whose inrush current does not exceed NEMA410 standards for electronic ballast/driver

System Communication

- Operates using Clear Connect RF Technology for reliable wireless communication; refer to model number chart on page 1 for frequency band details
- RF range is 30 ft (9 m)
- Wireless sensors and controls must be located within 60 ft (18 m) line of sight, or 30 ft (9 m), through walls, of the associated control module. The 60 ft (18 m) range is not reduced by a ceiling tile obstruction.

Environment

- Ambient operating temperature: 32 °F to 104 °F (0 °C to 40 °C)
- 0% to 90% humidity, non-condensing
- For indoor use only
- All drivers and ballasts used with Vive wireless controls must comply with the limits for a Class A device pursuant to Part 15 of the FCC Rules

0–10 V \equiv Control Link

- Communicates with up to 60 mA of fixtures
- Control link is IEC SELV/NEC Class 2
- 0–10 V \equiv control can be installed using NEC Class 1 or Class 2 wiring methods. Alternately, it can be wired to basic or double-insulated devices
- Terminals accept one 18 AWG to 16 AWG (0.75 mm² to 1.5 mm²) solid wire
- Always consult local wiring codes
- Compatible with ANSI E1.3 2001 (R2006), IEC 60929 Annex E

Job Name: Job Number:	Model Numbers:
------------------------------	----------------

Specifications *(continued)*

Default Operation

- Associated wireless input devices control all connected fixtures together
- Occupancy Sensors:
 - Occupied: 100%; Unoccupied: 0% (OFF)
- Pico Remote Controls:
 - On: 100%; Favorite Level: 50%; Off: 0% (OFF)
- Daylight Sensor: Decreases electric light in response to additional available daylight

Key Design Features

- LED status indicator shows load status and provides programming feedback
- Configurable high-end and low-end trim
- Power failure memory: If power is interrupted, connected loads will return to the previous level prior to interruption
- 0–10 V_{DC} control mis-wire protection up to 30 V_{DC}

Advanced Configurations

Pico Remote Controls

- Up to 10 Pico remote controls
- Favorite levels can be set for each Pico remote control

Radio Powr Savr Daylight Sensor

- The Radio Powr Savr daylight sensor will affect all connected ballast and LED drivers equally
- For multiple rows of daylighting, a separate PowPak Dimming Module with 0–10 V_{DC} must be used for each daylighting row

Minimum Light Level Setting (optional)

- Certain applications, such as hallways, may require that the lights never turn off. For these areas, select the minimum light level option and the load will lower to programmed low-end level. Default operation lowers to OFF.

High- and Low-End Trim

- High-end and low-end trim affect all connected fixtures equally, and can be configured from the PowPak Dimming Module.
- Adjustable low-end trim (0%–45%). Trimmable low-end can ensure a stable light level. Some fixtures will flicker or drop out if trimmed too low.
- The maximum light output of connected fixtures can be decreased down to 55% for energy savings in over-lit spaces.

Note: The perceived light output of low-end trim may vary between fixture manufacturers and model numbers. For best results, do not mix different ballasts or drivers on the same 0–10 V_{DC} circuit.

Radio Powr Savr Occupancy Sensors

- Radio Powr Savr occupancy and vacancy sensors control all connected ballasts or drivers.
- Pico remote controls can be used to adjust the Occupied levels of fixtures that they control from 1% to 100% (of output signal) or can make them unaffected by Occupancy events.
- Vacancy events (area becomes unoccupied) turn all ballasts and driver models off or to minimum light level.

Job Name: Job Number:	Model Numbers:
------------------------------	----------------

System Diagram (RMJS- and URMJS- models)

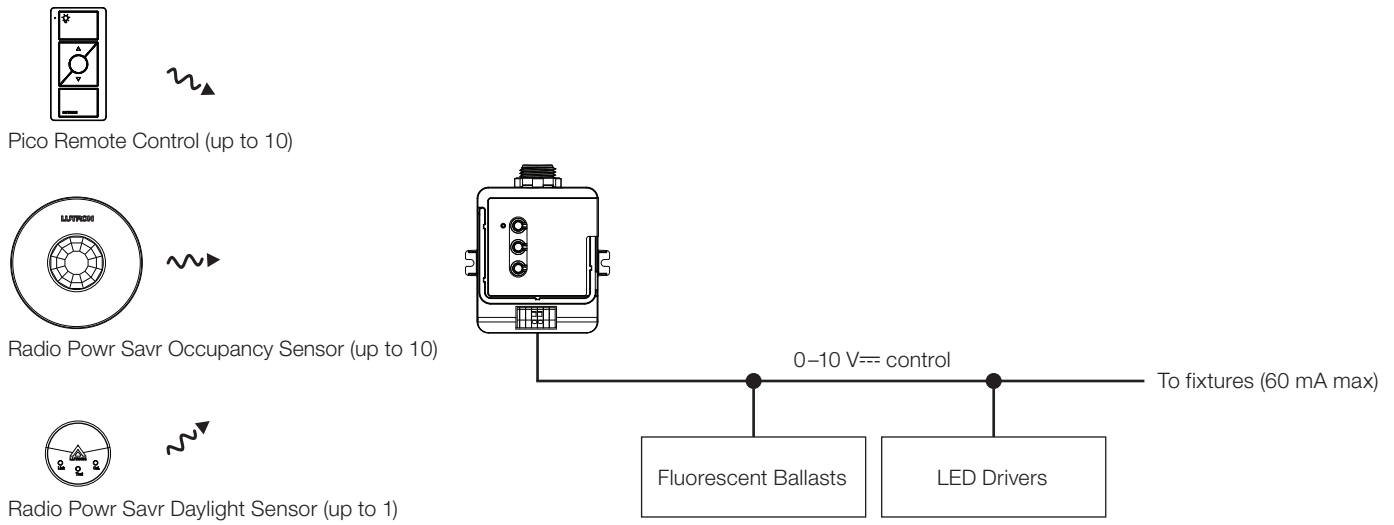

Wiring Schematic (RMJS- and URMJS- models)

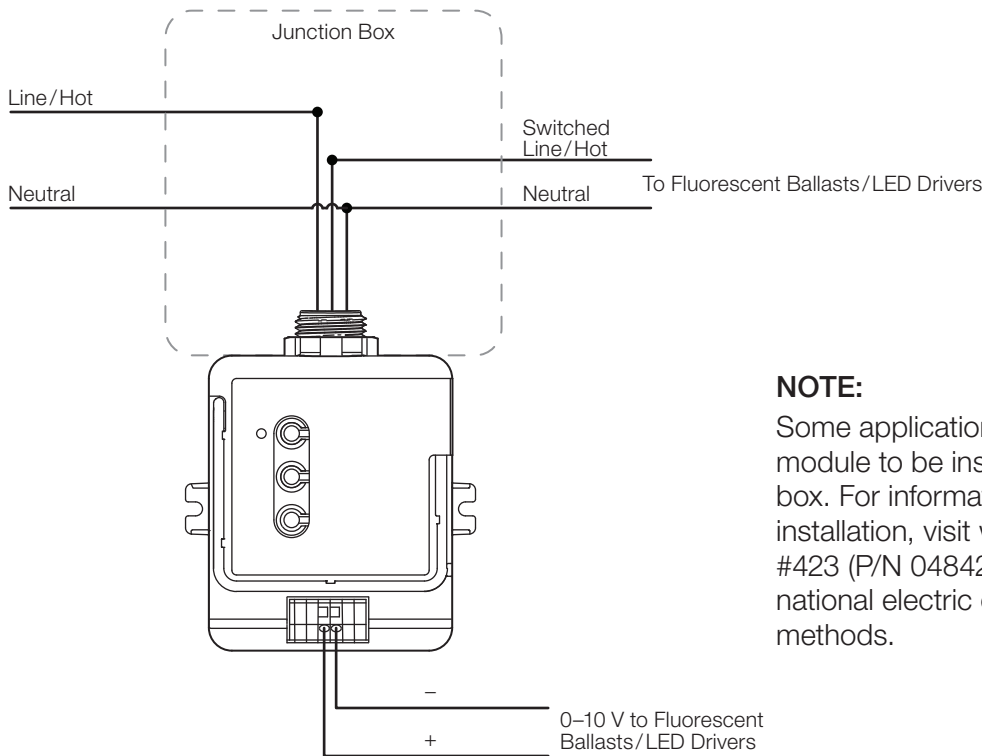

NOTE:

Some applications (in the U.S.A.) require the PowPak module to be installed inside an additional junction box. For information about how to perform this installation, visit www.lutron.com, Application Note #423 (P/N 048423). Please consult all local and national electric codes for proper installation methods.

Job Name:	Model Numbers:
Job Number:	

Dimensions

Dimensions are shown as: in (mm)

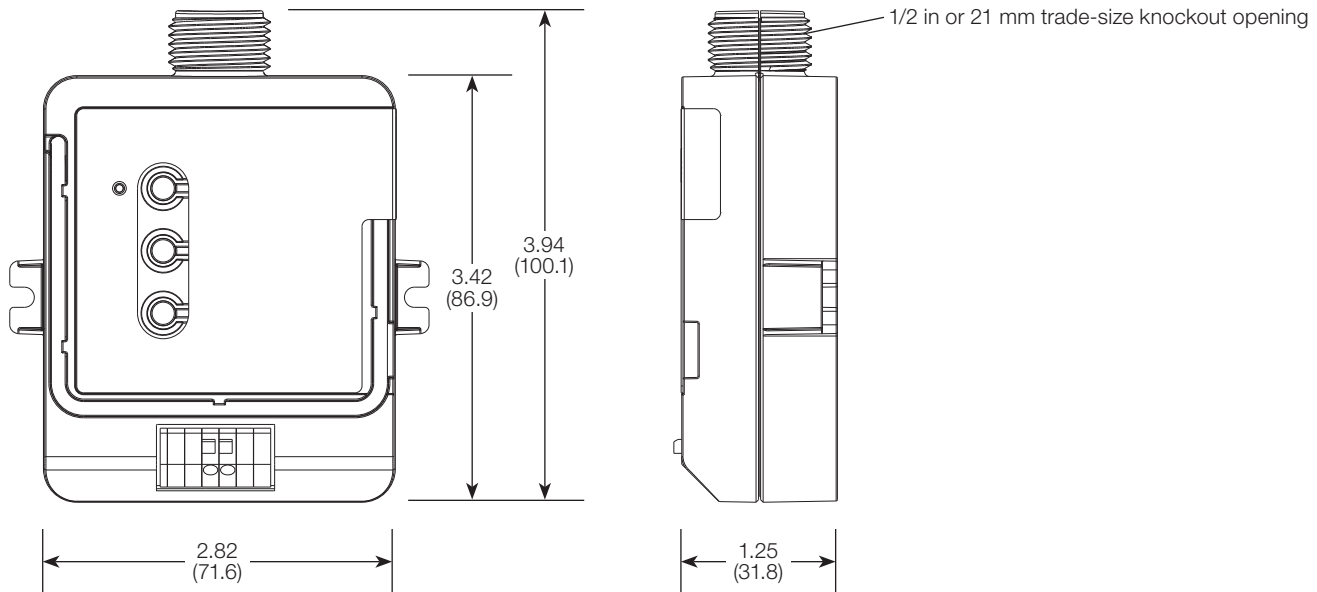

Range Diagram

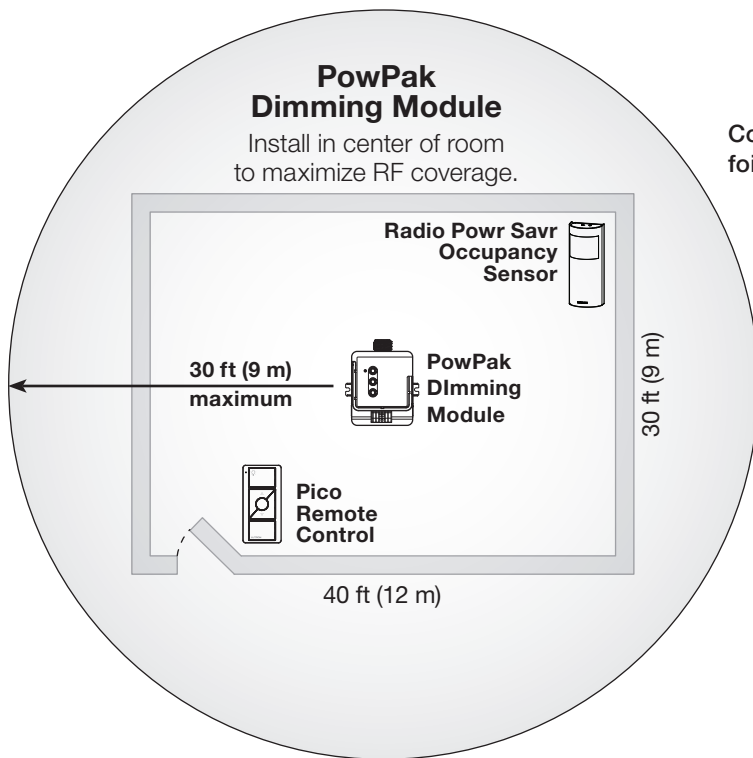

Contact Lutron first for applications using foil-backed or metallic ceiling tiles.

NOTE: Wireless sensors and controls must be located within 60 ft (18 m) line of sight, or 30 ft (9 m), through walls, of the associated control module. The 60 ft (18 m) range is not reduced by a ceiling tile obstruction.

Lutron, Lutron, PowPak, Clear Connect, and Pico are trademarks of Lutron Electronics Co., Inc. registered in the U.S. and other countries
Radio Powr Savr and Vive are trademarks of Lutron Electronics Co., Inc.

Job Name:	Model Numbers:
Job Number:	