

LED Neon Snap End Cap Installation



Warnings

- Before making any cuts or performing installation/maintenance, be sure all electricity is disconnected.
- Operate LED Neon lighting according to instructions only.
- Confirm the polarity of connectors before inserting.
- Connect and cut this product correctly. Must use cutting shears designed to cut LED Neon (listed in accessories tab).

Caution

- Use only factory-recommended shears, connectors, and accessories.
- Do not operate in more than 45°C (110°F) ambient temperature.
- Do not operate light when ambient temperature is below 0°C (32°F).
- Incorrect operation will damage the circuitry

Cutting Instructions

1. Use only the recommended shears (see accessories tab)
2. Place the LED Neon on a horizontal surface when cutting (cut perpendicular to light surface and only cut where the indicated cutting lines are printed)

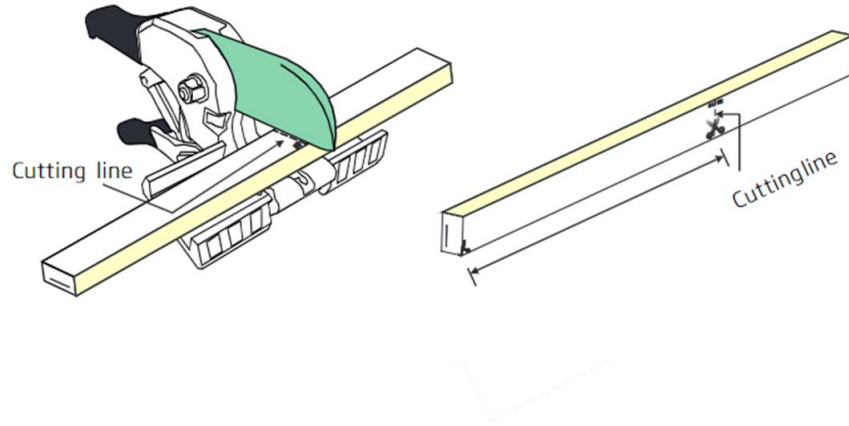

Snap End Cap Installation Instructions

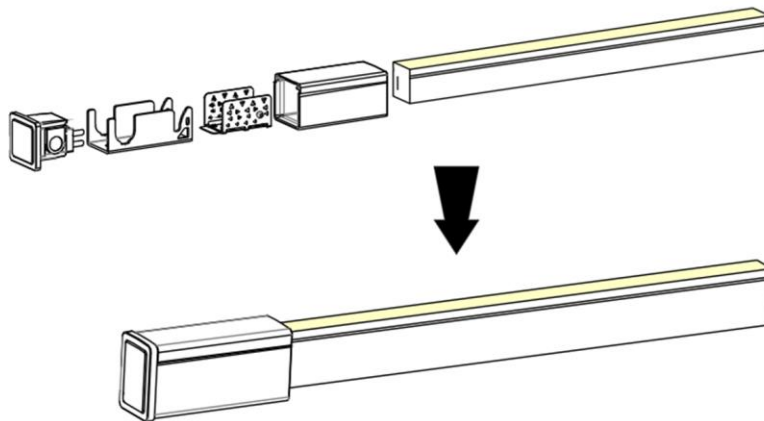

1. Slide the snap cover onto the neon with the arrow on the cover pointing towards the cut end.

Pay attention to the direction marked on the bottom of PC cover.

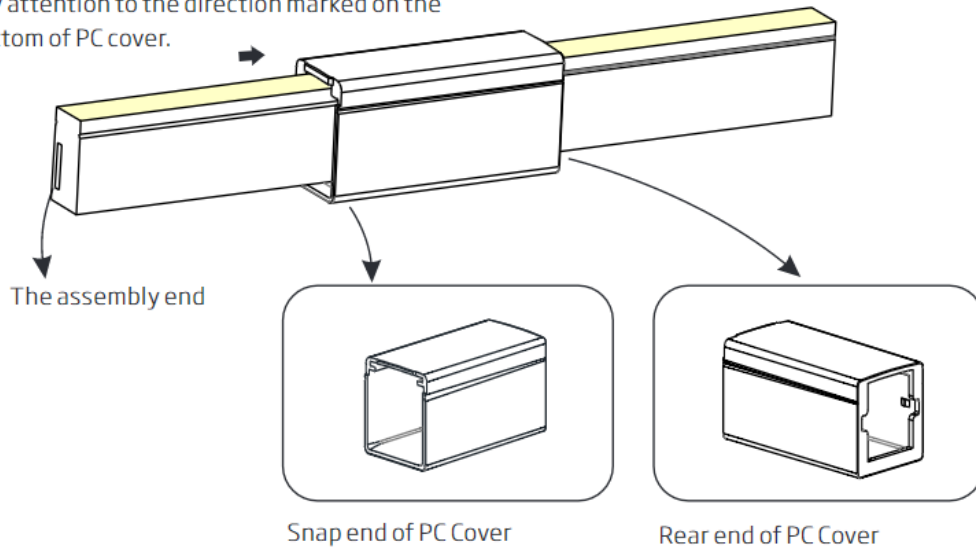

2. Insert the placement tool on the back side of the PCB and gently move the tool side to side to create enough space for the connector pins.

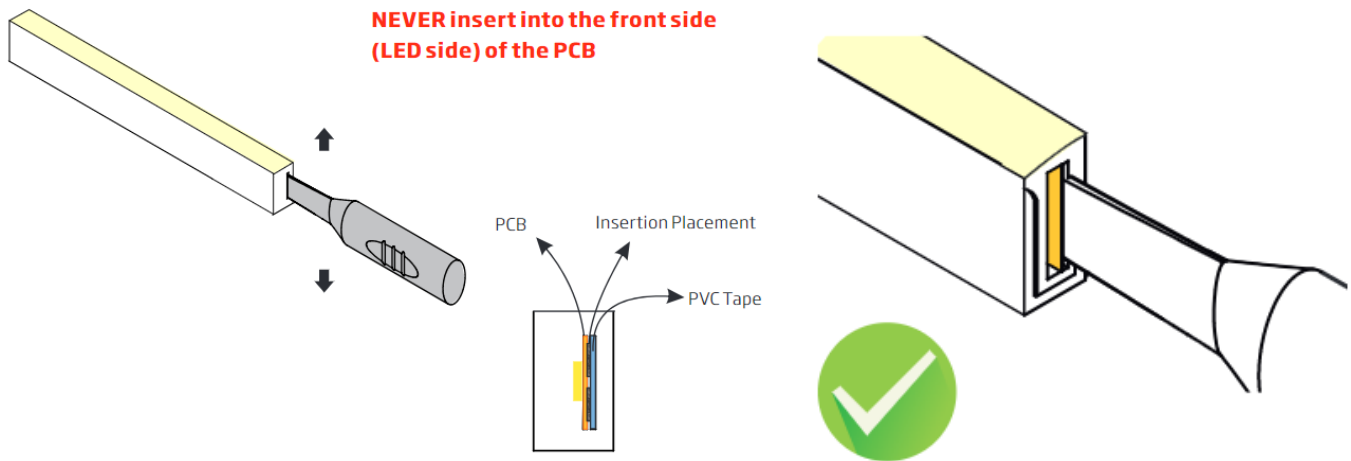

3. Insert the connector pins on the back side of the PCB. A small 2-5mm gap will exist between the connector and the neon surface. This gap will be eliminated once the metal bracket is in place.

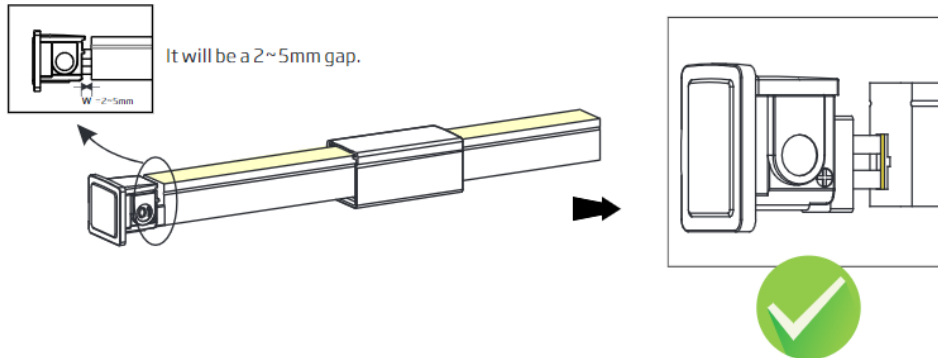

The following operations are prohibited:

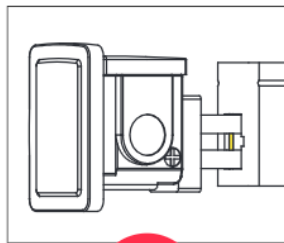

Insert into the front side of the PCB

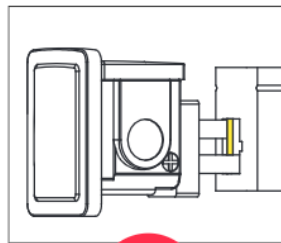

Insert crosswise into the PCB

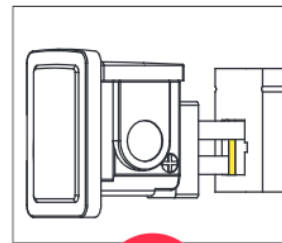

Insert crosswise into the PCB

4. Install the anti-skidding clip onto the neon ensuring that it lines up with the cutting edge.



Unfold the anti-skidding clip about 20 degrees on both sides.

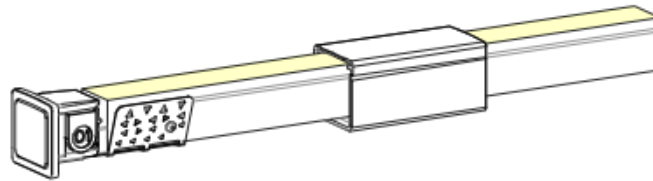

Place the anti-skidding clip onto the assembly end of the light.
Pay attention to its direction

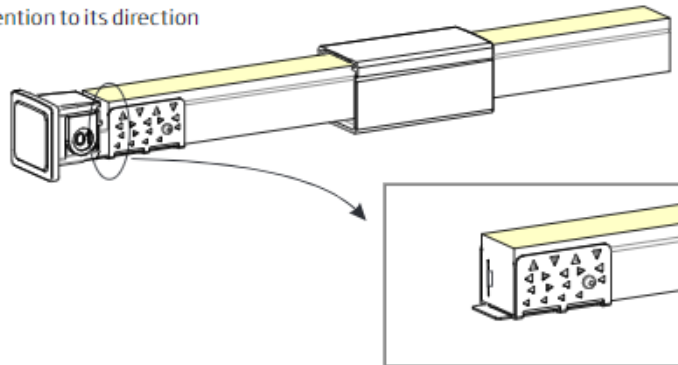

Fit the anti-skidding clip to the end of so that it wraps tightly and
its brim is aligned with the cut edge on both sides.

5. Slide the metal bracket over the entire assembly ensuring that the gaps in the plate properly align with the protrusions on both of the installed pieces.

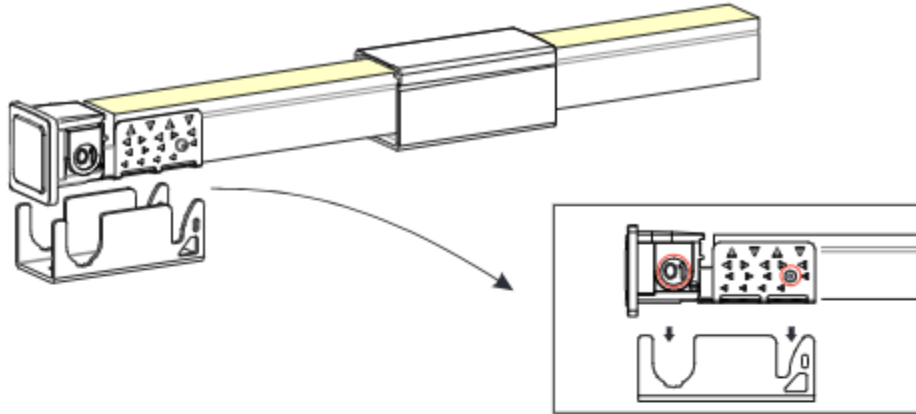

Align the tail plug and anti-skidding clip with the U steel plate.

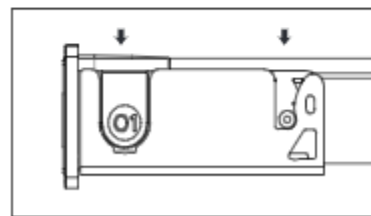
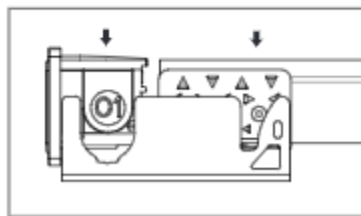
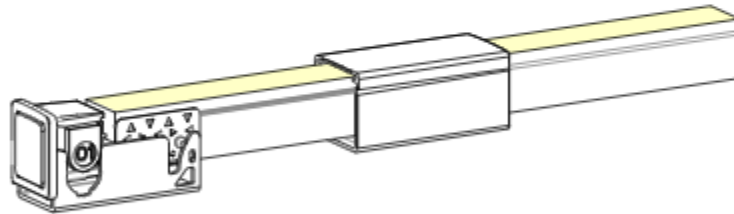

Press the tail plug and light downwards at the same time till bottom.

- Slide the snap cover towards the connector until it snaps into place.

